

Name _____

Date _____

LESSON 3.1

Practice B

For use with pages 146-152

Think of each segment in the diagram as part of a line. Complete the statement with *parallel*, *skew*, or *perpendicular*.

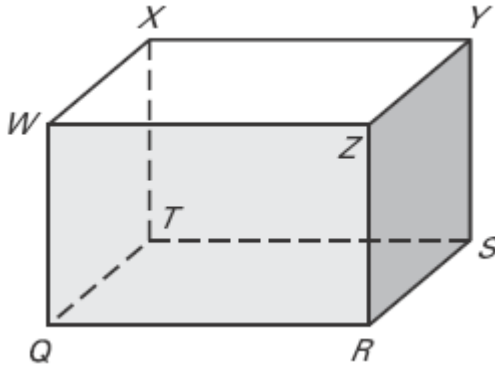

1. \overleftrightarrow{WZ} and \overleftrightarrow{ZR} are ? .
2. \overleftrightarrow{WZ} and \overleftrightarrow{ST} are ? .
3. \overleftrightarrow{QT} and \overleftrightarrow{YS} are ? .
4. Plane WZR and plane SYZ are ? .
5. Plane RQT and plane YXW are ? .

Think of each segment in the diagram as part of a line. Which line(s) or plane(s) appear to fit the description?

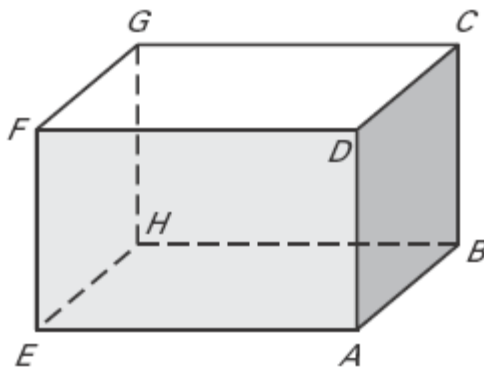

6. Line(s) parallel to \overleftrightarrow{EH}
7. Line(s) perpendicular to \overleftrightarrow{EH}
8. Line(s) skew to \overleftrightarrow{CD} and containing point F
9. Plane(s) perpendicular to plane AEH
10. Plane(s) parallel to plane FGC

Classify the angle pair as *corresponding*, *alternate interior*, *alternate exterior*, or *consecutive interior* angles.

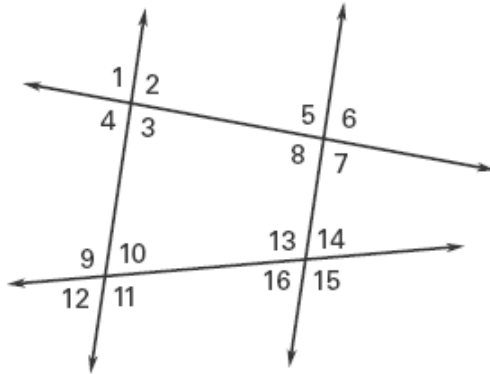

11. $\angle 1$ and $\angle 9$

12. $\angle 8$ and $\angle 13$

13. $\angle 6$ and $\angle 16$

14. $\angle 4$ and $\angle 10$

15. $\angle 8$ and $\angle 16$

16. $\angle 10$ and $\angle 13$

In Exercises 17-20, use the markings in the diagram.

17. Name a pair of parallel lines.

18. Name a pair of perpendicular lines.

19. Is $\overleftrightarrow{OL} \parallel \overleftrightarrow{TR}$? Explain.

20. Is $\overleftrightarrow{QL} \perp \overleftrightarrow{TR}$? Explain.

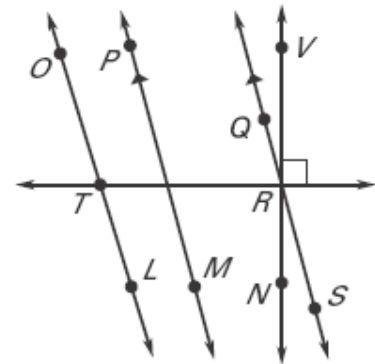

Use the diagram of the fire escape to decide whether the statement is *true* or *false*.

21. The planes containing the platforms outside of each pair of windows are parallel to the ground.

22. The planes containing the stairs are parallel to each other.

23. The planes containing the platforms outside of each pair of windows are perpendicular to the planes containing the stairs.

24. The planes containing the platform outside of each pair of windows are perpendicular to the plane containing the side of the building.

